



CLWT-067

BENCHTOP, CLOSED LOOP WIND TUNNEL FOR ELEVATED TEMPERATURE TESTING OF BOARDS AND COMPONENTS

The CLWT-067 is a research-quality closed loop wind tunnel that provides a convenient, accurate system for thermally characterizing PCBs and individual components at controlled temperatures from ambient to 85°C.

The CLWT-067 wind tunnel produces air flows up to 7.5 m/s (1500 ft/min). With customization, it can generate flows up to 50 m/s (10,000 ft/min) using orifice plates (available optionally). The clear Lexan test section lets the user to view the test specimen and allows for flow visualization.

Unlike open loop wind tunnels, the CLWT-067 re-circulates internal air. This allows the system heater to quickly warm the air to a specific temperature. The testing of boards and components in hot air is a requirement in some NEBS and other standards. The precise controls and temperature range of the CLWT-067 wind tunnel allows its use for testing heat sink performance and for calibrating air and temperature sensors.

The complete wind tunnel fits on most lab benches and is powered from standard AC outlets. It has a smaller footprint than traditional, closed loop wind tunnels or environmental test chambers.

The wind tunnel's test section can be accessed from the top door for mounting and repositioning of boards, components and sensors. Internal rail guides provide an easy mechanism to install test specimens of different sizes (e.g., PCB, heat sink).

Instrument ports (6) are provided in the front and side walls of the test section for placing temperature and velocity sensors such as thermocouples, Pitot tubes and hot-wire anemometers.

Custom options are also available. Contact ATS for details.

*RoHS Compliant

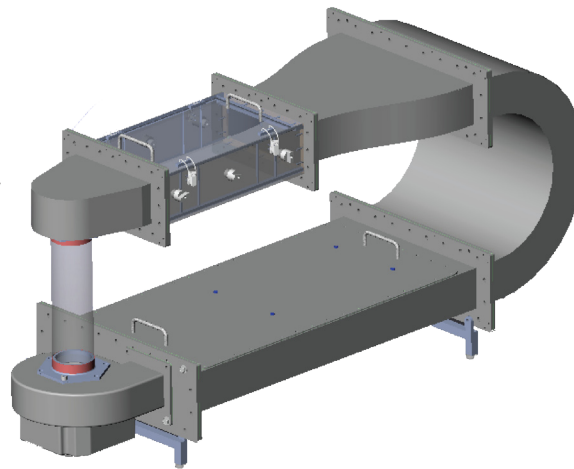

OVERALL DIMENSIONS (L X W X H)

143.6 cm x 49.3 cm x 67.7 cm
(56.5" x 19.4" x 26.6")

TEST SECTION DIMENSIONS

41.8 cm x 22.5 cm x 9.5 cm
(16.4" x 8.9" x 3.7")

MATERIALS

ALUMINUM, PLEXIGLAS

FLOW RANGE

0 TO 7.5 m/s (1500 ft/min)

TEMPERATURE RANGE

Up to 85°C (185°F)

WEIGHT

70.7 kg (156 lbs.)

FEATURES:

» Quick Access

Quickly change the test specimen through the front access test section

» Sensor Ports

Measure pressure, velocity and temperature through the sensor ports

» Data Center

View data and monitor events (with optional controller)

» Flow Characteristics

High quality flow with very low turbulence intensity

APPLICATIONS:

» High Temperature Testing

Evaluate the effects of elevated temperatures on component and PCB response and reliability

» Heat Sink Characterization

Characterize a variety of heat sink sizes for natural and forced convection cooling

» Sensor Calibration

Precision temperature and velocity controls allow accurate calibration of sensors

» Component Testing

Utilize for individual or multiple component testing

» Multiple PCB Testing

Test actual or simulated PCBs for thermal and flow distribution

For further technical information, please contact Advanced Thermal Solutions, Inc. at **1-781-769-2800** or **www.qats.com**