

# Heat Transfer Analysis of

## Compact Heat Exchangers Using Standard Curves



In previous issues of Qpedia Thermal eMagazine [1,2], we covered some fundamental and practical aspects of heat exchangers. In this issue, we will concentrate on compact heat exchangers and how to use standard curves for heat transfer analysis. Compact heat exchangers are a class of heat exchangers which features at least one of the fluids, on one side, as a gas. They generally have a very large heat transfer area per unit volume ( $>700 \text{ m}^2/\text{m}^3$ ) [3]. Most of the applications of compact heat exchangers are in the area of electronics cooling, because space for a cooling device is typically at a premium. Generally, the heat exchangers used in electronics cooling are of the air-to-liquid type. The heat transfer coefficient on the air side is significantly smaller than the liquid side, hence increasing the surface area on the air side can compensate for the low value of the heat transfer coefficient. Compact heat exchangers can come in different shapes and forms [3]. They can be made as

- Flat tubes (liquid) – continuous plate (air)
- Round tube (liquid) – continuous flat plate (air)
- Round tube (liquid) – round disks (air)
- Flat plate (liquid) – folded fin (air) single pass or multi-pass

Flow passages are generally very small (hydraulic diameter  $D_h < 5 \text{ mm}$ ) and the flow is considered laminar. Kays and

London [4] have compiled a large volume of data for different heat exchanger configurations. The data plotted is in the form of the Colburn factor ( $J_H$ ) and friction factor as a function of Reynolds number ( $Re$ ), as shown in figure 1. The Colburn  $J_H$  factor is defined as:

$$J_H = StPr^{2/3}$$

Where,

The Stanton number is defined as:

$$St = \frac{Nu}{RePr}$$

$Nu$ ,  $Re$  and  $Pr$  are Nusselt, Reynolds and Prandtl numbers, respectively.

After considering all of the constraints and identifying the heat exchanger type, the engineer must look at the graphs and match the heat exchanger configuration to the available data, if it is available, and extract the information from there.

The following example shows how to use curves to solve a heat exchanger problem:

Consider a circular tube-circular fin compact heat exchanger as shown in figure 1.

The liquid water transfers the heat from hot components through the aluminum tube. Ambient air is blown through the fins attached to the tubes to remove the heat from hot fluid. Calculating the overall heat transfer coefficient on the air side:

The geometrical dimensions of this heat exchanger and other information are as follows:

Tube outside diameter = 9.65 mm

Fin pitch = 343 per m

Flow passage hydraulic diameter =  $3.929 \times 10^{-3}$  m

Fin thickness =  $0.46 \times 10^{-3}$  m

Free flow area/frontal area =  $\frac{A_{ff}}{A_{fr}} = \sigma = 0.524$

Heat transfer area/total volume =  $\alpha = 0.524$

Fin area/total area =  $\frac{A_f}{A} = 0.91$

Inside tube diameter = 6 mm

- $\dot{m}_c$  = air mass flow rate (cold side) = 0.45 Kg/s

- $\dot{m}_h$  = water mass flow rate (cold side) = 0.1 Kg/s

$T_{air}$  = air flow temperature = 20 °C

$A_{fr}$  = frontal area = 0.0225 m<sup>2</sup>

The properties of air at 20 °C are as follows:

$C_p = 1007$  J/Kg.K

$\mu = 180 \times 10^{-7}$  N.s / m<sup>2</sup>

Pr = 0.709

The overall heat transfer coefficient for a heat exchanger is written as:

$$\frac{1}{UA} = \frac{1}{(\eta_0 h A)_c} + R_w + \frac{1}{(\eta_0 h A)_h} + R''_f \quad (1)$$

The fin effectiveness  $\eta_0$  can be written as:

$$\eta_0 = 1 - \frac{A_f}{A} (1 - \eta_f) \quad (2)$$

Where,

$A_f$  = fin area

$A$  = total heat transfer area

$\eta_f$  = fin efficiency

$h$  = heat transfer coefficient

$R_w$  = conduction resistance due to tube walls

$R''_f$  = fouling resistance

Subscripts c and h stand for cold and hot side, respectively.

Neglecting the fouling resistance

$R''_f = 0$

Since there are no fins inside the tubes  $\eta_{0,h} = 1$ , the subscript h means water is the hot fluid. The overall heat transfer coefficient, for the air which is directed to the cold side, can then be written as:

$$\frac{1}{U_c} = \frac{1}{\eta_{0,c} h_c} + R_w A_c + \frac{1}{h_h (A_h / A_c)} \quad (3)$$

$$A_h / A_c \approx D_i / D_o (1 - A_f / A)$$

$D_i$  = inner diameter of the tube

$D_o$  = outer diameter of the tube

The conduction resistance is calculated as:

$$R_w A_c = \frac{\ln\left(\frac{D_o}{D_i}\right)}{2\pi L k / A_c} = \frac{D_i \ln(D_o / D_i)}{2KA_h / A_c} = \frac{6 \times 10^{-3} \ln(9.65/6)}{2(200)(0.0559)} = 0.127 \times 10^{-3} \text{ m}^2 \cdot \text{K} / \text{W} \quad (4)$$

The heat transfer coefficient of the water flow inside the tube is calculated as:

$$U_{water} = \dot{m} / \rho A = \frac{0.1}{1000 \times \pi / 4 \times (6 \times 10^{-3})^2} = 3.5 \text{ m} / \text{s}$$

$$Re = \frac{\rho U_{water} D_h}{\mu} = 3.5(6 \times 10^{-3}) / 352 \times 10^{-6} = 59$$

This shows the flow is laminar. Assuming it is also fully

developed:

$Nu = \text{Nusselt number} = 4.26$

$$h_{\text{water}} = kNu/D = 0.67(4.26)/6 \times 10^{-3} = 486 \text{ W/m}^2 \cdot \text{K}$$

Now calculate the air side heat transfer coefficient:

$$Re_{\text{air}} = \frac{\rho U_{\text{air}} D_h}{\mu}$$

$U_{\text{air}}$  is the air flow velocity in the free flow area

$$\rho U_{\text{air}} = \frac{\dot{m}_{\text{air}}}{A_{\text{ff}}} = \frac{\dot{m}_{\text{air}}}{\sigma A_{\text{fr}}} = \frac{0.45}{0.524(0.0225)} = 38.16 \text{ Kg/m}^2 \cdot \text{S}$$

$$Re_{\text{air}} = \frac{38.16(3.929 \times 10^{-3})}{180 \times 10^{-7}} = 8329$$

From figure 1 [4], the Colburn factor  $J_H$  is found as:

$$J_H = 0.006$$

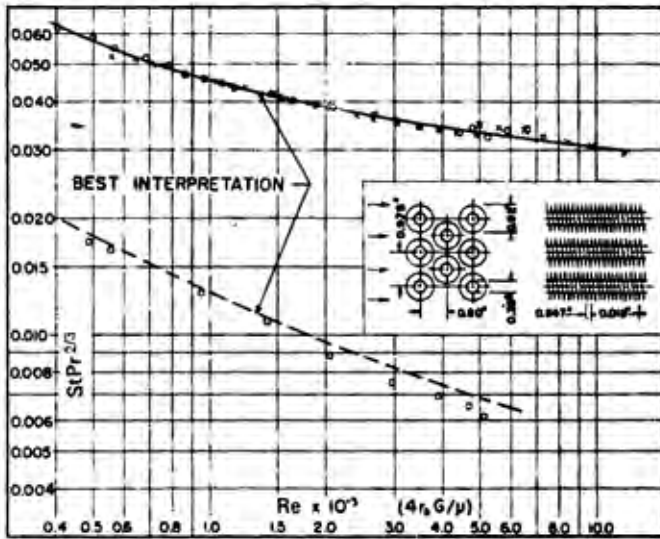

Figure 1. Colburn  $J_H$  Factor as a Function of Reynolds Number for Circular Tubes, Surface CF-8.72 [4].

The air side (cold side) heat transfer coefficient is then calculated as:

$$h_c \approx 0.006 \frac{GC_p}{Pr^{2/3}} = 0.006 \frac{38.16 \times 1007}{0.709^{2/3}} = 289 \text{ W/m}^2 \cdot \text{K}$$

Where,

$G = \text{Volumetric flow rate}$

$C_p = \text{Heat capacity}$

Calculate the fin effectiveness from Equation 2. First we need the fin efficiency. Referring to figure 2:

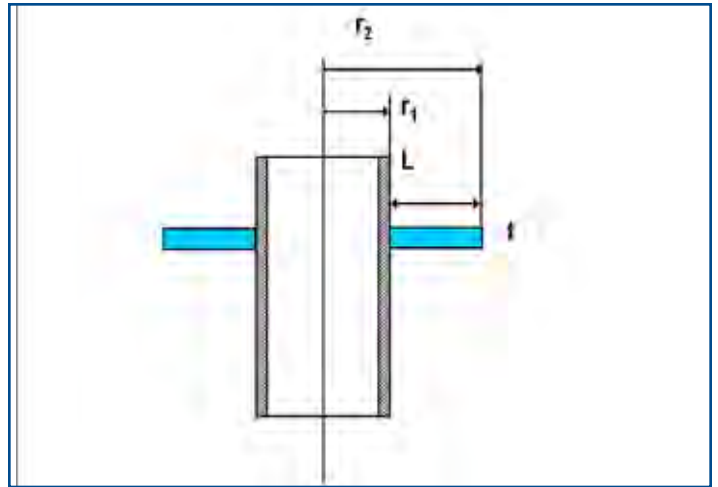
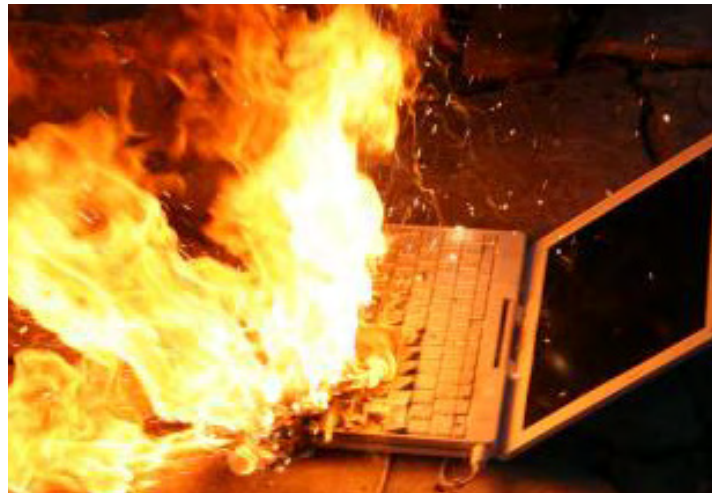

Figure 2. Schematic of Annular Fins of Rectangular Profile.



# Is it hot in there?

LEARN MORE ABOUT ATS' THERMAL DESIGN AND TESTING SERVICES BY VISITING [WWW.QATS.COM](http://WWW.QATS.COM) OR CALL 781.769.2800.

Advanced Thermal Solutions, Inc.  
89-27 Access Road | Norwood, MA | 02062 | USA  
T: 781.769.2800 | F: 769.769.9979 | [www.qats.com](http://www.qats.com)



From figure (3.19) in reference [3], we can find the fin efficiency as a function of  $LC^{3/2}(h/KA_p)^{1/2}$  for different values of  $r_{2c}/r_1$ . The variables are defined as:

$$r_{2c} = r_2 + t/2 = 11.914 \text{ mm}$$

$$L_c = L + t/2 = 7.089 \text{ mm}$$

$$A_p = L_c t = 1.63 \times 10^{-6}$$

$$L_c^{3/2}(h/KA_p)^{1/2} = 0.561 \text{ and } r_{2c}/r_1 = 2.46$$

$$\eta_{0,c} = 1 - A_f / A(1 - \eta_f) = 0.772$$

Finally the overall heat transfer coefficient is calculated as:

$$\frac{1}{U_c} = \frac{1}{486 \times 0.0559} + 0.127 \times 10^{-3} + \frac{1}{0.772 \times 289}$$

Overall heat transfer coefficient on the air side (cold side):

$$U_c = 23.5 \text{ W/m}^2 \cdot \text{K}$$

In future articles we will show analytical techniques for heat exchangers, with geometries that are not referenced in any available literature, especially compact heat exchangers with

very dense fins on the air side. Also, the above procedure simplified the analysis by ignoring the fouling factor. Fouling is the process of accumulation of particles on the fins or inside the liquid tubes. It depends on the fluid velocity, length of service and the type of fluid. In future articles, we will devote the topic to Fouling.

## References

1. Advanced Thermal Solutions, Inc., Qpedia Thermal eMagazine, May 2007, "Heat exchangers: theory and selection"
2. Advanced Thermal Solutions, Inc., Qpedia Thermal eMagazine, Jan 2008, "Compact heat exchangers for electronics cooling"
3. Incropera, F.P, Dewitt, D.P, "Introduction to heat transfer" 1985
4. Kays, M. and London, "Compact Heat Exchangers", Third Edition, McGraw-Hill, 1984.

# Boards running hot?

LET THE EXPERTS AT ATS SHOW YOU HOW TO ENSURE PRODUCT RELIABILITY, SPEED TIME-TO-MARKET AND REDUCE COSTS WITH EXPERT THERMAL MANAGEMENT ANALYSIS AND DESIGN SERVICES.

Advanced Thermal Solutions, Inc.

89-27 Access Road | Norwood, MA | 02062 | USA

T: 781.769.2800 | F: 769.769.9979 | www.qats.com



**ATS** ADVANCED  
THERMAL  
SOLUTIONS, INC.  
Innovations in Thermal Management®